

MITSUBISHI

AJ65BT-D75P2-S3

Positioning Module

User's Manual
(Hardware)

AJ65BT-D75P2-S3

Thank you for purchasing the Mitsubishi general-purpose programmable logic controller MELSEC-A series.

Prior to use, please read this and relevant manuals thoroughly to fully understand the product.



MODEL	AJ65BT-D75P2-U-HE
MODEL CODE	13JL48
IB(NA)-66829-E(1112)MEE	

● SAFETY PRECAUTIONS ●



(Read these precautions before using.)

When using Mitsubishi equipment, thoroughly read this manual and the associated manuals introduced in the manual. Also pay careful attention to safety and handle the module properly.

These precautions apply only to Mitsubishi equipment. Refer to the CPU module user's manual for a description of the programmable controller system safety precautions.

In this manual, the safety precautions are classified into two levels:

"⚠ WARNING" and "⚠ CAUTION".

 WARNING	Indicates that incorrect handling may cause hazardous conditions, resulting in death or severe injury.
 CAUTION	Indicates that incorrect handling may cause hazardous conditions, resulting in minor or moderate injury or property damage.

Under some circumstances, failure to observe the precautions given under "⚠ CAUTION" may lead to serious consequences.

Observe the precautions of both levels because they are important for personal and system safety.

Make sure that the end users read this manual and then keep the manual in a safe place for future reference.

[Design Precautions]

WARNING

- Install a safety circuit external to the programmable controller that keeps the entire system safe even when there are problems with the external power supply or the programmable controller main module.
An accident may occur by a false output or a malfunction.
 - 1) Configure interlock circuits such as an emergency stop circuit and high/low limits of positioning to prevent damages to the equipment.
Configure these circuits outside of the programmable controller.
 - 2) The zero return action is controlled by two kinds of data: the zero return direction and zero return speed. Since the system keeps operating without decelerating if a wrong zero return direction is set, apply damage prevention measures to the equipment.

[Design Precautions]

WARNING

- When data link becomes faulty, the operation of communication faulty station vary depending on its data link type. Configure an interlock circuit in the sequence program using the communication status information so the safety of the entire system is always maintained.
Refer to the manual of each data link for how to confirm communication faulty stations and the operation status during a communication error.

[Design Precaution]

CAUTION

- Do not bunch the control wires or communication cables with the main circuit or power wires, or install them close to each other.
They should be installed 100mm (3.9 in) or more from each other.
Not doing so could result in noise that would cause malfunction.

[Installation Precautions]

WARNING

- Use the programmable controller in an environment that meets the general specifications contained in this manual. Using this programmable controller in an environment outside the range of the general specifications could result in electric shock, fire, malfunction, and damage to or deterioration of the product.
- Tighten the module installation screws within the range of specified torque. If the module installation screws are loose, it may result in short circuits, fire or malfunction. Tightening the module installation screws too far may cause damages to the screws and /or the module, resulting in fallout, short circuits or malfunction.
- Do not directly touch the module's conductive parts. Doing so could cause malfunction or trouble in the module.
- Securely install the connectors for the drive unit and peripheral devices into the module connectors until a clicking sound comes. Improper installation may cause false contact, resulting in false input and output.
- When the drive unit and peripheral device are not connected, be sure to attach the connector cover. Failure to do so may cause malfunction.

[Wiring/Connection Precautions]

CAUTION

- Be sure to shut off all phases of the external power supply used by the system before installation or wiring.
Not doing so can cause the product to be damaged or malfunction.
- Be sure to ground the FG terminal to the class-D (class-3) or higher grounding. Otherwise there will be a danger of malfunctions.
- Use applicable solderless terminals and tighten them with the specified torque. If any solderless spade terminal is used, it may be disconnected when the terminal screw comes loose, resulting in failure.
- When wiring the programmable controller, check the rated voltage and terminal layout of the wiring, and make sure the wiring is done correctly. Connecting a power supply that differs from the rated voltage or wiring it incorrectly may cause fire or failure.
- Be sure to confirm terminal assignments before wiring the module.
- Be sure there are no foreign substances such as sawdust or wiring debris inside the module. Such debris could cause fire, failure or malfunction.
- Tighten the terminal screws with the specified torque. Loose terminal screws may cause a short circuit, fire or erroneous operation. Tightening the terminal screws too far may cause damage to the screws and /or the module, resulting in fallout, short circuits, or malfunction.
- Before beginning any installation or wiring work, make sure all phases of the power supply have been obstructed from the outside. Failure to completely shut off the power supply phases may cause electric shock and/or damage to the module.
- When turning on the power or operating the module after installation or wiring work, be sure the module's terminal covers are correctly attached. Failure to attach the terminal covers may result in electric shock.
- External connectors shall be correctly soldered. Imperfect connections could result in short circuit or erroneous operation.
- When connecting the communication and power supply cables to the module, always run them in conduits or clamp them.
Not doing so can damage the module and cables due to loose, moved or accidentally pulled cables or can cause a malfunction due to a cable connection fault.
- Do not install the control lines together with the communication cables, or bring them close to each other. Failure to do so may cause malfunctions due to noise.

[Wiring/Connection Precautions]

CAUTION

- When disconnecting the communication and power supply cables from the module, do not hold and pull the cable part.
Disconnect the cables after loosening the screws in the portions connected to the module. Pulling the cables connected to the module can damage the module and cables or can cause a malfunction due to a cable connection fault.

[Startup and Maintenance Precautions]

CAUTION

- Do not touch the terminals without having the power supply shut down externally at all phases. Doing so may result in malfunctions.
- Do not disassemble or modify the modules.
Doing so could cause failure, malfunction, injury or fire.
- Do not drop the module or give it hard impact since its case is made of resin. Doing so can damage the module.
- Make sure to switch all phases of the external power supply off before cleaning.
If you do not switch off the external power supply, it will cause failure or malfunction.
- Make sure to switch all phases of the external power supply off before mounting or removing the module. If you do not switch off the external power supply, it will cause failure or malfunction of the module.
- Before performing a test operation, set slow speed for the speed limit parameter value, and prepare to stop immediately in case any dangerous conditions occur.
- Do not install/remove the terminal block more than 50 times after the first use of the product. (IEC 61131-2 compliant)
- Before handling the module, always touch grounded metal, etc. to discharge static electricity from the human body.
Failure to do so can cause the module to fail or malfunction.

[Disposal Precautions]

CAUTION

- When disposing of this product, treat it as industrial waste.



● 安全注意事项 ●

(使用之前请务必阅读)

在使用本产品之前，应仔细阅读本手册以及本手册中所介绍的相关手册，同时在充分注意安全的前提下正确操作。

本手册中的注意事项仅记载与本产品有关的内容。

关于使用本产品的系统方面的安全注意事项，请参阅所使用的CPU模块的用户手册。

在“安全注意事项”中，安全注意事项被分为“ 警告”和“ 注意”两个等级。



警告

表示错误操作可能造成危险后果，导致死亡或重伤事故。

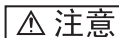

注意

表示错误操作可能造成危险后果，导致中度伤害、轻伤或财产损失。

此外，根据情况不同，即使标注为“ 注意”的事项也有可能引发严重后果。这两个等级的注意事项记载的均为重要内容，请务必遵守。

请妥善保管本手册以备需要时取阅，并将本手册交给最终用户。

【设计注意事项】

警告

- 应在可编程控制器外部设置一个安全电路，以保证整个系统在外部电源异常或可编程控制器本体故障时也能安全运行。否则可能由于误输出、误动作而导致事故发生。
 - (1) 应在可编程控制器外部配置紧急停止电路及定位的上限 / 下限等防止机械破损的互锁电路。
 - (2) 机械原点回归动作受到原点回归方向和原点回归速度二个数据的控制，通过近点狗ON开始减速。因此，如果原点方向设置错误，有可能不减速而继续运行，应采取防止机械破损的措施。
 - (3) 模块检测到出错时，将根据参数的停止组的设置进行通常的减速停止或紧急停止。应根据定位系统的规格设置参数。同时，应在参数设置值的范围内设置原点回归用参数及定位数据。

【设计注意事项】

警告

- 数据链接出现通信异常时，根据所使用的数据链接的种类，通信异常站的动作状态会有所不同。应使用通信状态信息，在顺控程序上配置互锁电路，以保证系统能安全运行。

注意

- 请勿将控制线及通信电缆与主电路及动力线等捆扎在一起或相互靠得太近。应相距大约100mm以上距离。因为噪声有可能导致误动作。

【安装注意事项】

⚠ 注意

- 应在本手册记载的一般规格环境下使用可编程控制器。
如果在一般规格范围以外的环境中使用可编程控制器，可能导致触电、火灾、误动作、产品损坏或性能劣化。
- 模块安装螺栓应在规定的扭矩范围内切实地拧紧。
如果模块安装螺栓拧得过松，有可能导致短路、火灾或误动作。
如果模块安装螺栓拧得过紧，有可能造成螺栓及模块破损从而导致掉落、短路或误动作。
- 请勿直接触碰模块的导电部分及电子部件。
否则可能导致模块误动作、故障。
- 外部设备连接用接口、外围设备连接接口应切实安装到模块的接口上，并确认发出“咔嗒”声。
如果未正确安装，有可能造成接触不良而导致误输入、误输出。
- 不连接驱动器模块及外围设备时，必须安装接口部的盖板。否则可能导致误动作。

【配线 / 连接注意事项】

⚠ 警告

- 进行可编程控制器配线作业时，应在确认产品的额定电压及端子排列的基础上正确进行操作。
如果连接了与额定值不符的电源或配线错误，可能导致火灾或故障。
- 进行模块配线作业时，应在确认端子排列的基础上正确进行操作。
- 应注意防止切屑及配线头等异物掉入模块内。
否则有可能导致火灾、故障或误动作。

⚠ 注意

- 必须将FG端子与可编程控制器的专用接地线连接。否则有可能导致误动作。
- 应在规定的扭矩范围内拧紧端子螺栓。
如果端子螺栓拧得过松，有可能导致短路、火灾或误动作。
如果端子螺栓拧得过紧，有可能造成螺栓及模块破损从而导致掉落、短路或误动作。
- 在安装、配线作业等时，必须从外部将电源全部断开后再进行操作。
如果未全部断开，有可能导致触电或产品损坏。
- 外部连接用接口应正确焊接。
如果连接不牢固，可能导致短路、误动作。
- 与模块相连接的电线及电缆必须收入套管中，或者用夹具进行固定处理。
如果未将电缆收入套管或未用夹具进行固定处理，可能由于电缆的晃动及移动、不经意的拉拽等造成模块破损、电缆接触不良而导致误动作。

【配线 / 连接注意事项】

△ 注意

- 请勿将控制线与通信电缆捆扎在一起或相互靠得太近。因为噪声有可能导致误动作。
- 在拆卸与模块相连接的电缆时，请勿用手拉扯电缆部分。带接口的电缆应握住与模块相连接部分的接口进行拆卸。
没有接口的电缆请在松开与模块相连接的部分的螺栓后再进行拆卸。如果在与模块连接的状态下拉扯电缆，可能造成模块及电缆破损、电缆接触不良而导致误动作。

【启动 / 维护注意事项】

△ 注意

- 在通电状态下请勿触摸端子。否则可能导致触电或误动作。
- 请勿拆解或改造模块。否则可能导致故障、误动作、人身伤害或火灾。
- 在清洁模块或重新紧固端子螺栓时，必须从外部将电源全部断开后再进行操作。如果未全部断开，有可能导致故障或误动作。
- 在控制盘内拆装模块时，必须从外部将电源全部断开后再进行操作。如果未全部断开，有可能导致模块故障或误动作。
- 试运行应在为速度限制参数设置一个低速值，并做好在发生危险情况时能够立即停止的准备后再进行动作确认。
- 产品投入使用后，端子排的拆装次数不应超过50次。（根据IEC61131-2规范）
- 在触碰模块之前，必须先触碰已接地的金属等，释放掉人体等所携带的静电。如果不释放掉静电，有可能导致模块故障或误动作。

【报废处理注意事项】

△ 注意

- 本产品报废时，应当作工业废物处理。

● CONDITIONS OF USE FOR THE PRODUCT ●

- (1) Mitsubishi programmable controller ("the PRODUCT") shall be used in conditions;
- i) where any problem, fault or failure occurring in the PRODUCT, if any, shall not lead to any major or serious accident; and
 - ii) where the backup and fail-safe function are systematically or automatically provided outside of the PRODUCT for the case of any problem, fault or failure occurring in the PRODUCT.
- (2) The PRODUCT has been designed and manufactured for the purpose of being used in general industries.
- MITSUBISHI SHALL HAVE NO RESPONSIBILITY OR LIABILITY (INCLUDING, BUT NOT LIMITED TO ANY AND ALL RESPONSIBILITY OR LIABILITY BASED ON CONTRACT, WARRANTY, TORT, PRODUCT LIABILITY) FOR ANY INJURY OR DEATH TO PERSONS OR LOSS OR DAMAGE TO PROPERTY CAUSED BY the PRODUCT THAT ARE OPERATED OR USED IN APPLICATION NOT INTENDED OR EXCLUDED BY INSTRUCTIONS, PRECAUTIONS, OR WARNING CONTAINED IN MITSUBISHI'S USER, INSTRUCTION AND/OR SAFETY MANUALS, TECHNICAL BULLETINS AND GUIDELINES FOR the PRODUCT.
- ("Prohibited Application")
- Prohibited Applications include, but not limited to, the use of the PRODUCT in;
- Nuclear Power Plants and any other power plants operated by Power companies, and/or any other cases in which the public could be affected if any problem or fault occurs in the PRODUCT.
 - Railway companies or Public service purposes, and/or any other cases in which establishment of a special quality assurance system is required by the Purchaser or End User.
 - Aircraft or Aerospace, Medical applications, Train equipment, transport equipment such as Elevator and Escalator, Incineration and Fuel devices, Vehicles, Manned transportation, Equipment for Recreation and Amusement, and Safety devices, handling of Nuclear or Hazardous Materials or Chemicals, Mining and Drilling, and/or other applications where there is a significant risk of injury to the public or property.

Notwithstanding the above, restrictions Mitsubishi may in its sole discretion, authorize use of the PRODUCT in one or more of the Prohibited Applications, provided that the usage of the PRODUCT is limited only for the specific applications agreed to by Mitsubishi and provided further that no special quality assurance or fail-safe, redundant or other safety features which exceed the general specifications of the PRODUCTS are required. For details, please contact the Mitsubishi representative in your region.

ABOUT THE MANUALS

The following product are available for this equipment.
Refer to the table given below to choose suitable manuals.

Detailed manual

Manual name	Manual number (Model code)
AJ65BT-D75P2-S3 Positioning Module User's Manual	IB-66824 (13JL46)

Related Manual

Manual name	Manual number (Model code)
Positioning module software package type SW11VD-AD75P Operating Manual	IB-66714 (13J915)
CC-Link System Master Local type AJ61BT11/A1SJ61BT11 Module User's Manual	IB-66721 (13J872)
CC-Link System Master Local Module type AJ61QBT11/A1SJ61QBT11 User's Manual	IB-66722 (13J873)
CC-Link System Master/Local type QJ61BT11N Module User's Manual	SH-080394E (13JR64)

COMPLIANCE WITH THE EMC AND LOW VOLTAGE DIRECTIVES

1) Method of ensuring compliance

To ensure that Mitsubishi programmable controllers maintain EMC and Low Voltage Directives when incorporated into other machinery or equipment, certain measures may be necessary. Please refer to one of the following manuals.

- QCPU User's Manual (Hardware Design, Maintenance and Inspection)
- Safety Guidelines

(This manual is included with the CPU module or base unit.)

The CE mark on the side of the programmable controller indicates compliance with EMC and Low Voltage Directives.

2) Additional measures

To ensure that this product maintains EMC and Low Voltage Directives, please refer to one of the manuals listed under (1).

CONTENTS

1. OVERVIEW	1
2. PERFORMANCE SPECIFICATIONS	1
3. NAME OF EACH PART	2
4. LOADING AND INSTALLATION	4
4.1 Handling precautions.....	4
4.2 Installation environment	4
5. WIRING DATA-LINK CABLES	5
5.1 Precautionary items when handling twisted cables.....	5
5.2 Wiring a twisted cable	5
6. EXTERNAL WIRING	6
6.1 Precautionary notes when wiring	6
6.2 I/O Interface.....	7
7. EXTERNAL DIMENSIONS	10

1. OVERVIEW

This manual describes how to install AJ65BT-D75P2-S3 Positioning Module (hereafter abbreviated as D75P2) and how to wire them with external devices.

IMPORTANT

- 1) The following software packages will be needed if a D75P2 is to be used:
For DOS/V personal computers : SW1IVD-AD75P or later
- 2) Software version D or later will be required for AD75TU.

After unpacking D75P2, please confirm that the following products are contained.

Model name	Quantity
(Main module) AJ65BT-D75P2-S3	1
(Connector for external wiring) 10136-3000VE	2
(Connector cover) 10336-52F0-008	2

2. PERFORMANCE SPECIFICATIONS

The performance specifications for the D75P2 are shown below.
Refer to CPU module User's Manual to use for D75P2 general specifications.

Item	Specifications
Maximum output pulse	When connected to a differential driver: 400kpps When connected to an open collector: 200kpps
Maximum connection distance between servos	When connected to a differential driver: 10m (32.81 ft.) When connected to an open collector: 2m(6.56 ft.)
Type of CC-Link station	Intelligent device station
Number of occupied station	4 stations (RX/Ry each 128 points, RWr/RWw each 16 points)
External power supply	24 V DC (20.4 to 26.4 V DC)
Applicable wire size	0.75 to 2.00 mm ²
Module installation screws	Over M4 × 0.7 mm(0.03 in) × 16 mm(0.6 in) DIN rail attachment is possible
Applicable DIN rails	TH35-7.5Fe, TH35-7.5Al, TH35-15Fe (conforms to JIS-C2B12)
Applicable solderless terminal	RAV 1.25-3.5, RAV 2-3.5
24 V DC internal current consumption	0.30 A
Noise durability	Noise voltage 500 Vp-p, noise width 1 μs (by the noise simulator with the noise frequency 25 to 60 Hz)
Dielectric withstand voltage	Batch power supply/communication type-batch external I/O, 500 V AC for 1 minute
Insulation resistor	Batch power supply /communication type batch external I/O, 500 V DC 10 m Ω or more by the insulation resistance tester.
External dimensions	63.5[2.5](H) × 170[6.7](W) × 80[3.1](D) mm [inch]
Weight	0.50 [1.1] kg [lb]

3. NAME OF EACH PART

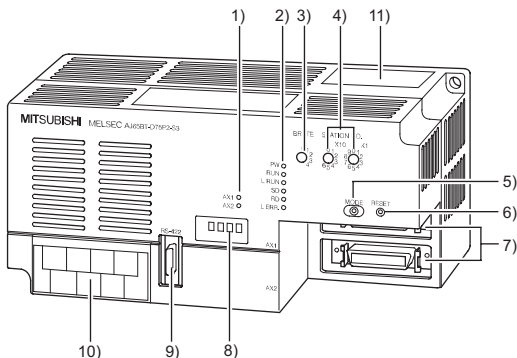

No.	Name	Description																
1)	Corresponding axis LED display	Indicates the axis for the "8) 17 segment LED" message.																
2)	CC-Link status LED display	Shows the power supply and data communication conditions.																
3)	Transmission speed setting switch	Sets the data communication speed.																
4)	Station number setting switch	Sets the D75P2 station number.																
5)	LED display mode select switch	Display information is switched between "1) Corresponding axis LED display" and "8) 17 segment LED" each time the switch is pressed.																
6)	Reset switch	When pressed, it initializes input signals, remote registers and operation processing.																
7)	Drive unit connectors (AX1, AX2)	For connection to the drive unit, mechanical system input and manual pulse generator.																
8)	17 segment LED ^{*1}	Displays messages indicating the operation status according to the mode.																
9)	RS-422 peripheral connector	For connection to peripheral devices.																
10)	Terminal block	For connection to the master module. <div style="text-align: center;"> Terminal block assignment diagram <table border="1" style="margin: auto;"> <tr> <td>1</td> <td>3</td> <td>5</td> <td>7</td> </tr> <tr> <td>DA</td> <td>DG</td> <td>+24V</td> <td>24G</td> </tr> <tr> <td>2</td> <td>4</td> <td>6</td> <td>8</td> </tr> <tr> <td>DB</td> <td>SLD</td> <td>(FG)</td> <td></td> </tr> </table> </div>	1	3	5	7	DA	DG	+24V	24G	2	4	6	8	DB	SLD	(FG)	
1	3	5	7															
DA	DG	+24V	24G															
2	4	6	8															
DB	SLD	(FG)																
11)	Maintenance connector for manufacturer	This connector is for manufacturer use only. Do not open the cover.																

- *1 For modules of the hardware version L or later, the display part is changed to a LED module. (The display contents remain the same as the 17-segment LED.)

Before change

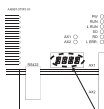

17 segment

Example of
display: IDL

After change

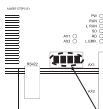

LED module

Example of
display: IDL

4. LOADING AND INSTALLATION

The following is explanations of the handling precautions and installation environment which is common to modules when handling D75P2 from unpacking to installation.

For the details of loading and installation of the module, refer to User's Manual of programmable controller CPU module to be used.

4.1 Handling precautions

- 1) The module case is made of plastic. Be sure not to drop it or subject it to strong vibration.
- 2) Do not remove the printed circuit board of the module from the case. This may cause malfunctions.
- 3) Be careful not to let foreign matters such as filings or wire chips get inside the module during wiring. When such matters do enter, be sure to remove them.
- 4) Tighten the module installation screws and terminal screws within the following tightening torque range.

Screw	Tightening Torque Range
Module installation screws (M4 screws)	0.78 to 1.18N•m (6.9 to 10.4lbinch)
Terminal screws	0.59 to 0.88N•m (5.2 to 7.8lbinch)
Terminal block installation screws (M4 screws)	0.78 to 1.18N•m (6.9 to 10.4lbinch)

4.2 Installation environment

Do not install the A series programmable controller in the following environments.

- 1) Where the ambient temperature exceeds the 0 to 55°C range.
- 2) Where the ambient humidity exceeds the 10 to 90 % RH range.
- 3) Where condensation is produced by sudden temperature changes.
- 4) Where corrosive or combustible gas is present.
- 5) Where dust, iron powder and other conductive powder, oil mist, salt, or organic solvents are prevalent.
- 6) In direct sunlight.
- 7) Where a strong electric or magnetic field is generated.
- 8) Where vibration and shock may be transmitted directly to the module.

5. WIRING DATA-LINK CABLES

This section describes the method for wiring a twisted cable between the D75P2 and master module.

5.1 Precautionary items when handling twisted cables

Do not handle the twisted cables in the following manner. These extreme activities will damage the cables.

- 1) Applying pressure using a sharp object.
- 2) Twisting the cable extensively.
- 3) Pulling the cable with an extremely large force (more than tolerable tension).
- 4) Stepping on the cable.
- 5) Placing any object atop.
- 6) Scratching the cable cover.

5.2 Wiring a twisted cable

Wire the twisted cable between the D75P2 and master module in the following manner:

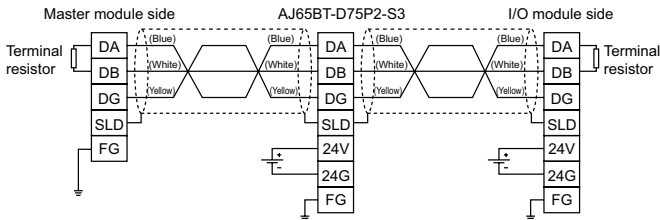

6. EXTERNAL WIRING

Precautionary notes when wiring as well as the I/O interface are described below.

6.1 Precautionary notes when wiring

This section describes the precautionary notes for the wiring process between the D75P2 and outside (drive unit).

- (1) Length of connection cable between the D75P2 and drive unit
 - (a) When an open collector is used, the maximum cable length is 2 m (6.56 ft.). However, this value might change according to the drive unit specifications.
Perform wiring after verifying the specifications for the drive unit to be used.
 - (b) When a differential driver is used, the maximum cable length is 10 m (32.81 ft.).
To extend the distance between the D75P2 and drive unit, use a differential driver.
- (2) Wiring for I/O signals
 - (a) Avoid bundling with or installing near the proximity of power wires or main circuit wires.
 - (b) When installing near the proximity of power wires or main circuit wires, use separate ducts or piping.
 - (c) If bundling cannot be avoided, use a batch shielded cable and ground it on the programmable controller side.
 - (d) When wiring is done via piping, be sure to ground the pipe.
 - (e) If the connection cable is long or the main circuit wiring is in the proximity, operation error may occur due to noise.

6.2 I/O Interface

○ : Wiring required, △ : Wiring performed as required

I/O classification	External wiring	Pin number	Internal circuit	Signal name	Wiring requirement
Input		11		Near-point signal DOG	△
		12		High limit LS FLS	○
		13		Low limit LS RLS	○
		14		Stop signal STOP	△
		15		Speed/ position switch signal CHG	△
		16		External start STRT	△
		35		Common COM	○
		36			
		(+) 9		Manual pulser phase A PULSER A+ PULSER A-	△
		(-) 27			
		(+) 10		Manual pulser phase B PULSER B+ PULSER B-	△
		(-) 27			
		7		Drive unit ready READY	○
		8		In-position signal INPS	△
		26		Common COM	○
		6			
24		Zero-point signal PGO	△		
25		Common PGO COM			

I/O classification	External wiring	Pin number	Internal circuit	Signal name	Wiring requirement	
Output		5		Deviation counter clear	CLEAR	○
		23		Common	CLEAR COM	
		1		CW Phase A PULSE	PULSE F	○*1
		19			PULSE COM	
		2		CCW Phase B SIGN	PULSE R	
		20			PULSE COM	
		3(+)		CW Phase A PULSE	PULSE F +	○*1
		21(-)			PULSE F -	
		4(+)		CCW Phase B SIGN	PULSE R +	
		22(-)			PULSE R -	

*1 Select open collector output or differential output, according to the drive unit used.

Remarks

The following shows the relationship between the pulse output mode selected via the parameter and the pulse output according to "positive logic/negative logic selection."

Mode selection	Positive logic		Negative logic	
	Forward rotation	Reverse rotation	Forward rotation	Reverse rotation
CW CCW				
PULSE SIGN				
A ϕ B ϕ				

- * To construct an absolute position detection system, perform wiring as shown below:

I/O classification	External wiring	Pin No.	Internal circuit	Signal name [abbreviation]	
				When ABS transfer mode ON *2	When ABS transfer mode OFF *3 Upper level: MR-H Lower level: MR-J2
Input		17		ABS data bit0 [D01]	Positioning complete [PF] Positioning complete [D01]
		18		ABS data bit1 [ZSP]	Zero speed [ZSP]
		34		ABS transmission data preparation complete [TLC]	During torque control [TLC]
		33		Common [COM]	Common [COM]
Output		29		Servo ON [SON]	Servo ON [SON]
		30		ABS transfer mode [ABSM]	— [DI3] Proportional control [PC]
		31		ABS request [ABSR]	— [DI4] During torque control [TL]
		32		Common [COM]	Common [COM]

Remarks

- *2 Signals in the ABS transfer mode are shown.
- *3 Signals in the normal state (not in the ABS transfer mode) are shown. For details, refer to the specification/instruction manual for the servo amplifier used.

7. EXTERNAL DIMENSIONS

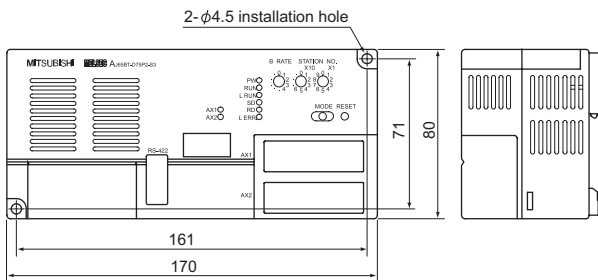
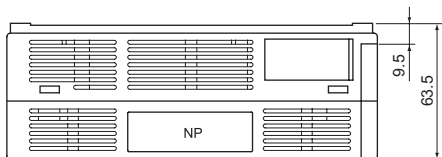

Unit:mm (inch)

Country/Region	Sales office/Tel	Country/Region	Sales office/Tel
U.S.A	Mitsubishi Electric Automation Inc. 500 Corporate Woods Parkway Vernon Hills, IL 60061, U.S.A. Tel : +1-847-478-2100	China	Mitsubishi Electric Automation (China) Ltd. 4/F Zhi Fu Plaza, No.80 Xin Chang Road, Shanghai 200003, China Tel : +86-21-6120-0808
Brazil	MELCO-TEC Rep. Com.e Assessoria Tecnica Ltda. Rua Correia Dias, 184, Edificio Paraiso Trade Center-8 andar Paraiso, Sao Paulo, SP Brazil Tel : +55-11-5908-8331	Taiwan	Setsuyo Enterprise Co., Ltd. 6F No.105 Wu-Kung 3rd.Rd, Wu-Ku Hsiang, Taipei Hsine, Taiwan Tel : +886-2-2299-2499
Germany	Mitsubishi Electric Europe B.V. German Branch Gothaer Strasse 8 D-40880 Ratingen, GERMANY Tel : +49-2102-486-0	Korea	Mitsubishi Electric Automation Korea Co., Ltd. 1480-6, Gayang-dong, Gangseo-ku Seoul 157-200, Korea Tel : +82-2-3660-9552
U.K	Mitsubishi Electric Europe B.V. UK Branch Travellers Lane, Hatfield, Hertfordshire., AL10 8XB, U.K. Tel : +44-1707-276100	Singapore	Mitsubishi Electric Asia Pte, Ltd. 307 Alexandra Road #05-01/02, Mitsubishi Electric Building, Singapore 159943 Tel : +65-6470-2480
Italy	Mitsubishi Electric Europe B.V. Italian Branch Centro Dir. Colleoni, Pal. Perseo-Ingr.2 Via Parcelso 12, I-20041 Agrate Brianza., Milano, Italy Tel : +39-039-60531	Thailand	Mitsubishi Electric Automation (Thailand) Co., Ltd. Bang-Chan Industrial Estate No.111 Moo 4, Serithai Rd, T.Kannayao, A.Kannayao, Bangkok 10230 Thailand Tel : +66-2-517-1326
Spain	Mitsubishi Electric Europe B.V. Spanish Branch Carretera de Rubi 76-80, E-08190 Sant Cugat del Valles, Barcelona, Spain Tel : +34-93-565-3131	Indonesia	P.T. Autoteknindo Sumber Makmur Muara Karang Selatan, Block A/Utara No.1 Kav. No.11 Kawasan Industri Pergudangan Jakarta - Utara 14440, P.O.Box 5045 Jakarta, 11050 Indonesia Tel : +62-21-6630833
France	Mitsubishi Electric Europe B.V. French Branch 25, Boulevard des Bouvets, F-92741 Nanterre Cedex, France Tel : +33-1-5568-5568	India	Messung Systems Pvt, Ltd. Electronic Sadan NO.III Unit No15, M.I.D.C Bhosari, Pune-411026, India Tel : +91-20-2712-3130
South Africa	Circuit Breaker Industries Ltd. Private Bag 2016, ZA-1600 Isando, South Africa Tel : +27-11-928-2000	Australia	Mitsubishi Electric Australia Pty. Ltd. 348 Victoria Road, Rydalmere, N.S.W 2116, Australia Tel : +61-2-9684-7777

MITSUBISHI ELECTRIC CORPORATION

HEAD OFFICE : TOKYO BUILDING, 2-7-3 MARUNOUCHI, CHYODA-KU, TOKYO 100-8310, JAPAN
NAGOYA WORKS : 1-14, YADA-MINAMI 5-CHOME, HIGASHI-KU, NAGOYA, JAPAN

When exported from Japan, this manual does not require application to the Ministry of Economy, Trade and Industry for service transaction permission.

Specifications subject to change without notice.